

**NEW-FLOW**

**ISO 9001  
REGISTERED**

# **NEW-FLOW**

## ***Instruction Manual***

MANUFACTURE OF BACK PRESSURE REGULATOR  
BPR SERIES-10  
AND CONTROL INSTRUMENTS



**Approvals:**

**CE 1128**



**NEW-FLOW TECHNOLOGIES, INC.**

No.9 Lane 133, Xing-Hua St., Chien Chen Dist., Kaohsiung 806, Taiwan

TEL: 886-7-8135500 FAX: 886-7-8225588 / 8159758

Email: [info@new-flow.com](mailto:info@new-flow.com) [www.new-flow.com](http://www.new-flow.com)

# INSTALLATION

## Technical Data

For using gas and liquid

**Inlet pressure:** 250 Psig maximum

**Adjustable inlet relief pressure in ranges:**

3~35; 6~85; 17~125; 20~216 Psig

**Operating temperature:** -40 to 175°C

**Diaphragm material:** 316L stainless steel

**Body material:** 316L stainless steel

**Seat material:** Viton, FFKM available

**CV flow coefficients:** 1.0

**Process connection:** 1/4" and 1/2" NPT female

**Two gauge connection ports are:** 1/4" NPT female

**Use no oil:** available

## Standard Port Configuration

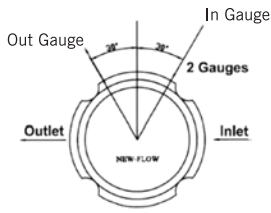

A

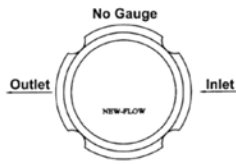

B

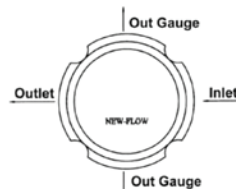

D

## Principle

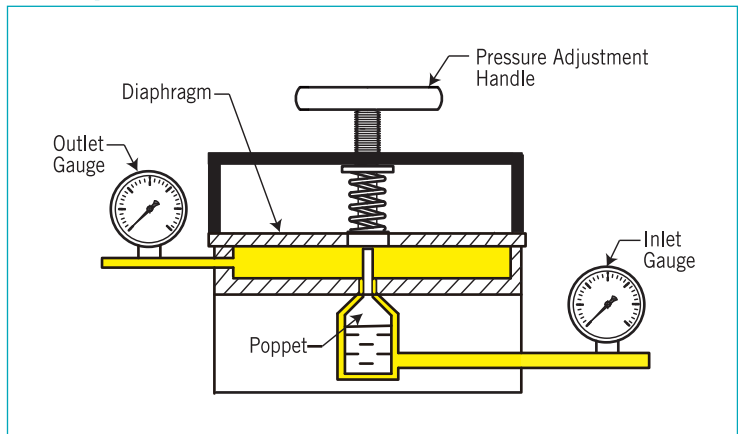

## Construction Drawing

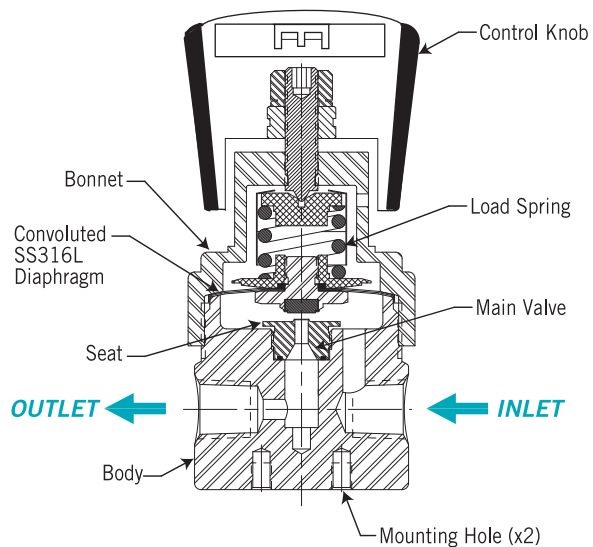

## Dimensions-mm

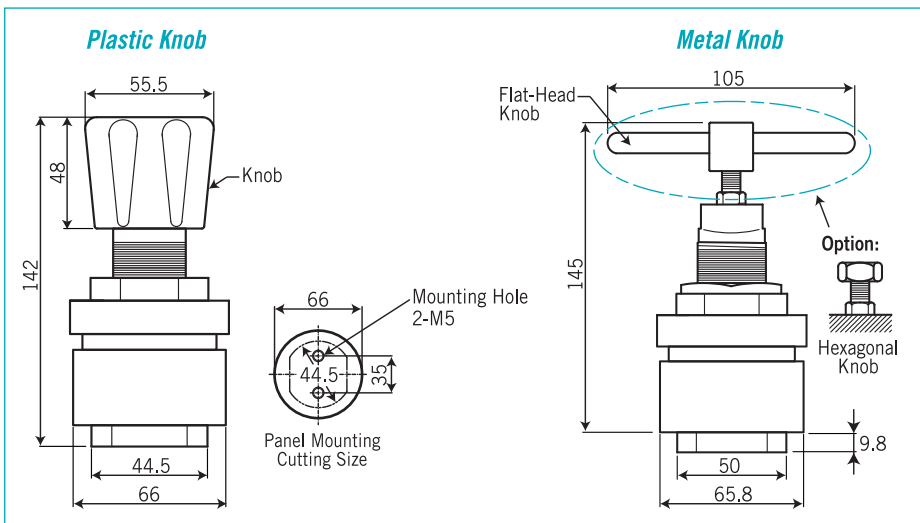

## Installation Mode

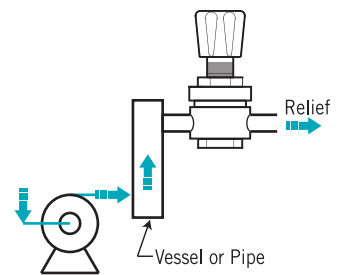

# INSTALLATION

## A. Installation

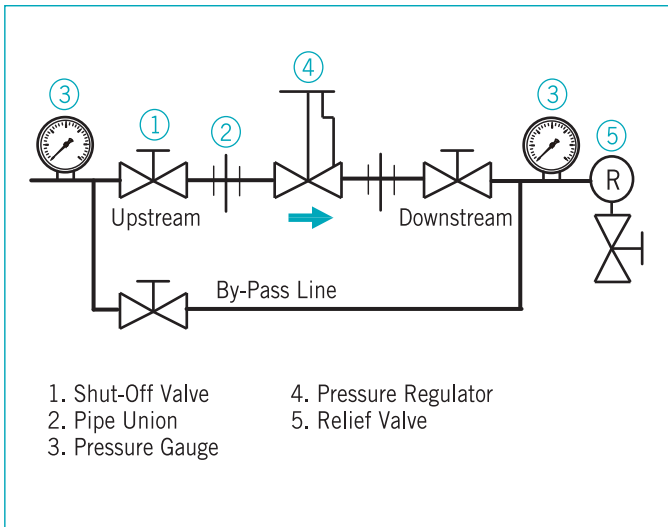

1. Before installing the pressure regulator, use an air compressor to clean out debris, welding scale, metal scraps and all other foreign materials inside pipes and components.
2. Install shut-off valves, pressure gauges, and by pass line according to the "Installation Diaphragm" for easy adjustment proper testing and operation.
3. When placing thread sealant on pipe ends, remove any excess thread sealant. Do Not allow any thread sealant to enter the pressure regulator and pipes.
4. Install a strainer at the entrance point of the pressure regulator (upstream side) to prevent debris and all other foreign materials from entering the pressure regulator. Use a strainer with size 0.033 screen mesh.
5. Install the pressure regulator at the highest point of a horizontal pipeline, so that upstream and downstream can have good emissions. By doing so it also prevents water hammer, and the pressure regulator can function effectively at regulating flow.
6. Align the arrow on the pressure regulator with the flow direction (flow through the pressure regulator is in the direction indicated by the arrow on the pressure regulator). Once direction is properly aligned, it does not affect the operation of the pressure regulator whether the regulator is installed horizontally or vertically.
7. To achieve the optimal performance, it is necessary to install a section of straight (not curved) 90cm (3.5") pipe at both upstream and downstream entrances of the pressure regulator. Straight pipes must be installed right at the entrance points.
8. If possible, please install a relief valve at downstream, and make the pressure setting of the relief valve 15psi higher than the pressure setting of the pressure regulator (that is 15psi higher than the set pressure).
9. If severe turbulent flow exists in pipes, it is recommended to accumulator.
10. The pressure regulator must operate within the allowable pressure and temperature limit.

## B. Startup and Adjustment

1. Open the downstream shut off valve completely (open all the way).
2. Slowly open the upstream shut off valve.
3. Slowly close and open the downstream shut-off valve several times to ensure the pressure regulator can operate smoothly.
4. While keeping the downstream shut-off valve open, slowly tighten the adjusting knob for pressure adjustment until the desired pressure set point shows up on the pressure range.
5. To change pressure setting, turn the adjusting knob clockwise to increase pressure and counterclockwise to reduce pressure.
6. To change pressure setting, because of the operation pressure is higher than the demand pressure, it has to turn on the relief valve and adjust the knob counterclockwise, and then turn off the relief valve. Repeat the step.5 again.

## C. Maintenance

### NOTE.:

Before uninstalling any component or connection, make sure that there is no more pressure inside the pressure regulator. Please follow the suggested steps below and "Installation Diaphragm" for maintenance:

1. Close the upstream shut off valve.
2. Release pressure inside the pressure regulator toward downstream. Be careful of not letting pressure flow backward toward upstream (backpressure).
3. Wait until the pressure regulator indicates zero pressure to close the downstream shut-of valve.

## D. Troubleshooting

### Problem scenario 1: Unstable control

It could be that:

- a.) Regulator valve size is too large. When valve size is too large, it can cause the fluid to flow backward, turbulence or hammering sound. It also causes a decrease in the usable pressure range. Please select a suitable pipe size.
- b.) The pressure regulator is clogged and cannot be close completely. It needs to be serviced or replaced.
- c.) Too much debris accumulated at plugs. Clean out the debris.

### Problem scenario 2: Unable to maintain pressure

(unable to maintain the pressure after pressure adjustment)

It could be that:

- a.) Filter or pipeline is clogged.
- b.) The valve size is too small for the requested flow rate.