

# 3-PIECE FLANGED BALL VALVE

NA3FC150-HL – ANSI 150LB  
 NA3FPN16-HL – DIN PN16

NA3FJ10K-HL – JIS 10K  
 NA3FPN40-HL – DIN PN40

– Without Mounting Pad

## Technical Data

- Full Port
  - Investment Casting
  - Design: ASME B16.34
  - Valves Inspected & Tested according to API 598 Standard
- Material: ANSI 150LB– ASTM-A351-CF8M, ASTM-A351-CF8, ASTM-A351-CF3M, ASTM-A216-WCB

JIS 10K– SCS 14A / SCS 13A  
 DIN PN16 & PN40– EN10213-1.4408, EN10213-1.4308, EN10213-1.4409, EN10213-1.0619

Working Pressure: ANSI Class 150 / JIS 10K / DIN PN16 / DIN PN40  
 Flange Dimension: ANSI B16.5 / JIS B2220 / EN1092-1  
 Face to Face Dimension: DIN3202 / F1 Type  
 Size Ranging: ½"~4" (DN15~DN100);  
 ½"~1½" (DN15~DN40) are common type with PN40  
 Option: Locking Device



## Dimensions

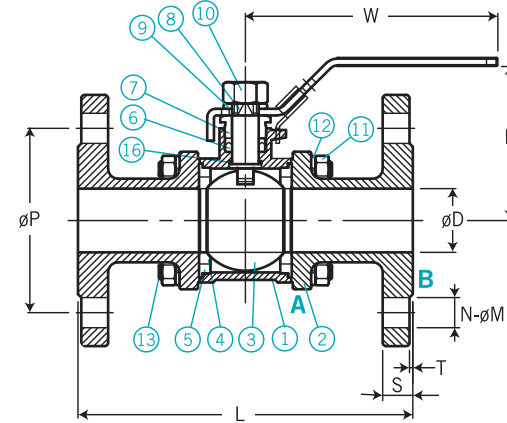
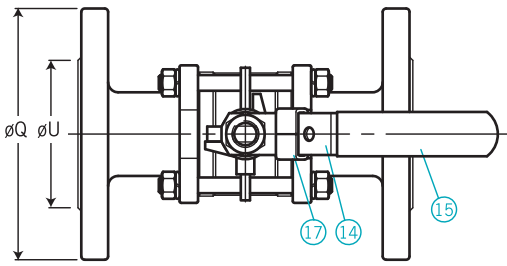

## Dimension Data

unit:mm

Size	øD	øP				øQ				S				T				H
		ANSI 150	JIS 10K	DIN PN16	DIN PN40	ANSI 150	JIS 10K	DIN PN16	DIN PN40	ANSI 150	JIS 10K	DIN PN16	DIN PN40	ANSI 150	JIS 10K	DIN PN16	DIN PN40	
1/2"	15	60.5	70	65	65	89	95	95	95	11.2	12	16	16	1.6	1	2	2	59
3/4"	20	70	75	75	75	98	100	105	105	11.2	14	18	18	1.6	1	2	2	62
1"	25	79.5	90	85	85	108	125	115	115	11.2	14	18	18	1.6	1	2	2	68
1¼"	32	89	100	100	100	117	135	140	140	12.7	16	18	18	1.6	2	2	2	88
1½"	38	98.5	105	110	110	127	140	150	150	14.3	16	18	18	1.6	2	3	3	100
2"	50	120.5	120	125	125	152	155	165	165	15.9	16	20	20	1.6	2	3	3	108
2½"	65	140	140	145	145	178	175	185	185	17.5	18	18	22	1.6	2	3	3	125
3"	80	152.5	150	160	160	190	185	200	200	19	18	20	24	1.6	2	3	3	136
4"	100	190.5	175	180	190	229	210	220	235	23.8	18	20	24	1.6	2	3	3	160

Size	øU				L	øM				N				W
	ANSI 150	JIS 10K	DIN PN16	DIN PN40		ANSI 150	JIS 10K	DIN PN16	DIN PN40	ANSI 150	JIS 10K	DIN PN16	DIN PN40	
1/2"	35	51	45	45	130	15.9	15	14	14	4	4	4	4	123
3/4"	43	56	58	58	150	15.9	15	14	14	4	4	4	4	123
1"	51	67	68	68	160	15.9	19	14	14	4	4	4	4	130
1¼"	64	76	78	78	180	15.9	19	18	18	4	4	4	4	130
1½"	73	81	88	88	200	15.9	19	18	18	4	4	4	4	152
2"	92	96	102	102	230	19.1	19	18	18	4	4	4	4	152
2½"	105	116	122	122	290	19.1	19	18	18	4	4	8	8	219.5
3"	127	126	138	138	310	19.1	19	18	18	4	8	8	8	250
4"	157	151	162	162	350	19.1	19	18	22	8	8	8	8	298

### Detail A.

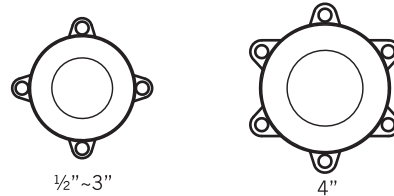

### Detail B.

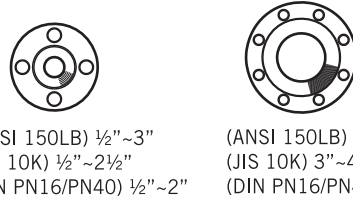

(ANSI 150LB) ½"~3"  
 (JIS 10K) ½"~2½"  
 (DIN PN16/PN40) ½"~2"

(ANSI 150LB) 4"  
 (JIS 10K) 3"~4"  
 (DIN PN16/PN40) 2½"~4"

## Pressure-Temperature Chart

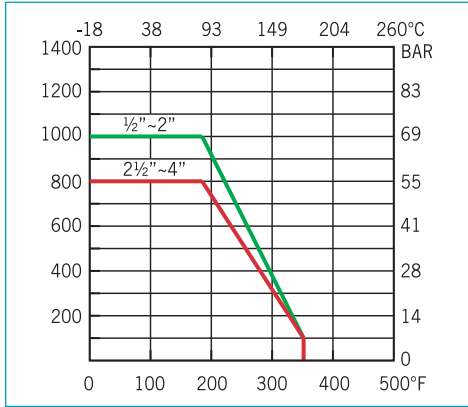

## Parts & Material List

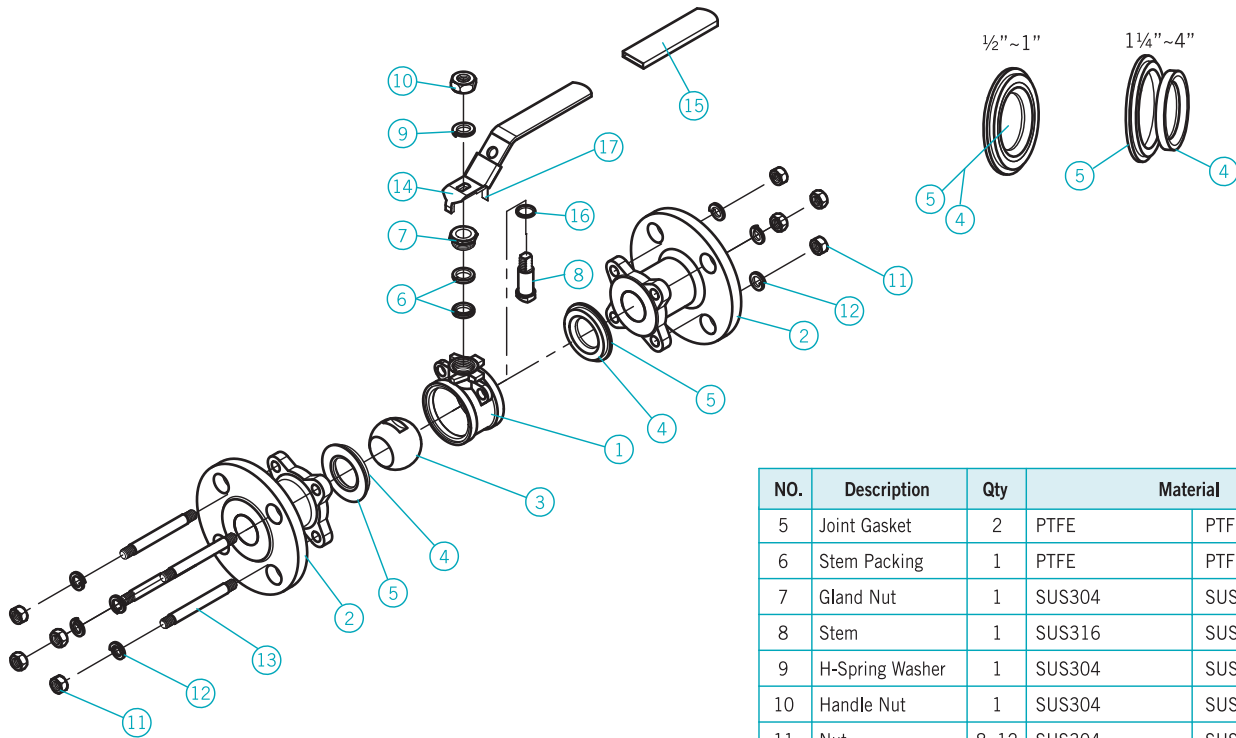

### Material List

NO.	Description	Qty	Material	
1	Body	1	ASTM-A351-CF8M	ASTM-A216-WCB
2	Cap	2	ASTM-A351-CF8M	ASTM-A216-WCB
3	Ball	1	ASTM-A351-CF8M	ASTM-A351-CF8
4	Seat	2	PTFE	PTFE

NO.	Description	Qty	Material	
5	Joint Gasket	2	PTFE	PTFE
6	Stem Packing	1	PTFE	PTFE
7	Gland Nut	1	SUS304	SUS304
8	Stem	1	SUS316	SUS304
9	H-Spring Washer	1	SUS304	SUS304
10	Handle Nut	1	SUS304	SUS304
11	Nut	8-12	SUS304	SUS304
12	Spring Washer	8-12	SUS304	SUS304
13	Bolt	4-6	SUS304	SUS304
14	Handle	1	SUS304	SUS304
15	Handle Cover	1	Plastic	Plastic
16	Thrust Washer	1	PTFE	PTFE
17	Locking Device	1	SUS304	SUS304

## Ordering Information

Model	Flange Rating	
NA3FC150-HL	ANSI Class 150	NA3FJ10K-HL JIS 10K
NA3FPN16-HL	DIN PN16	NA3FPN40-HL DIN PN40
↓	<b>Code</b>	<b>Connection Size</b>
		(1) 1/2" (2) 3/4" (3) 1" (4) 1 1/4" (5) 1 1/2" (6) 2" (7) 2 1/2" (8) 3" (9) 4"
	<b>Code</b>	<b>Body Material</b>
	ANSI	(1) ASTM-A351-CF8M (2) ASTM-A351-CF8 (3) ASTM-A351-CF3M (4) ASTM-A216-WCB
	JIS	(5) SCS 14A (6) SCS 13A
DIN	(7) EN10213-1.4408 (8) EN10213-1.4308 (9) EN10213-1.4409 (10) EN10213-1.0619	
		<b>Complete Ordering Code</b>

**Ordering code example:**  
**NA3FPN16-HL-3-DIN 10**  
 → NA3FPN16-HL= Model  
 → 3= Connection Size (DN25 PN16)  
 → DIN 10= Body Material (EN10213-1.0619)