

# ACTUATORS

## DA SERIES – Double Acting Actuators

## SA SERIES – Spring Return Actuators



DA Series



SA Series

Patent No.

M328561

### Technical Data

Operating Pressure Range: 40~120 psig

Maximum Allowable Working Pressure: 150 psig

Maximum Operating Pressure: 120 psi

Operating Media: Dry or lubricated non-corrosive gas

Operating temperature: Standard -40°F ~ +200°F

### Construction & Parts List

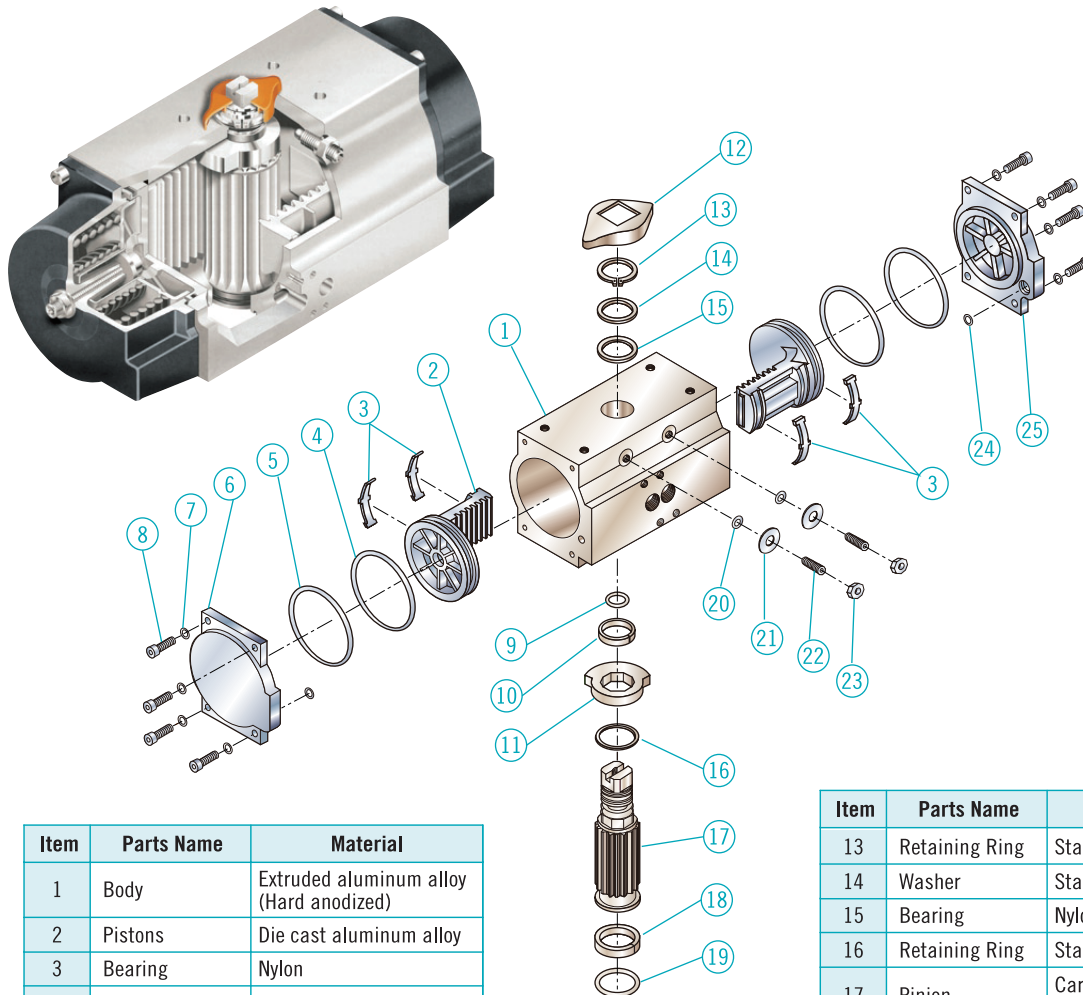

Item	Parts Name	Material
1	Body	Extruded aluminum alloy (Hard anodized)
2	Pistons	Die cast aluminum alloy
3	Bearing	Nylon
4	O-Ring	Buna-N
5	O-Ring	Buna-N
6	End Cap (L)	die cast aluminum alloy
7	Washer	Stainless steel
8	Cap Screw	Stainless steel
9	O-Ring	Buna-N
10	Bearing	Nylon
11	Stop Cam	Sinteral steel
12	Piston Indicator	Polyethylene

Item	Parts Name	Material
13	Retaining Ring	Stainless steel
14	Washer	Stainless steel
15	Bearing	Nylon
16	Retaining Ring	Stainless steel
17	Pinion	Carbon Steel (Electroless nickel plated)
18	Bearing	Nylon
19	O-Ring	Buna-N
20	O-Ring	Buna-N
21	Washer	Stainless steel
22	Stop Screw	Stainless steel
23	Nut	Stainless steel
24	O-Ring	Buna-N
25	End Cap (R)	Die cast aluminum alloy

## Operation Method

### A. Double-Acting (Top View)

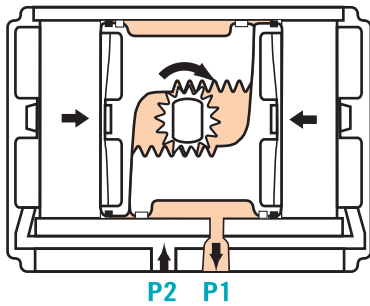

For clockwise output, apply pressure to P2, which force the pistons to move together. The volume between the pistons is exhausted at P1.

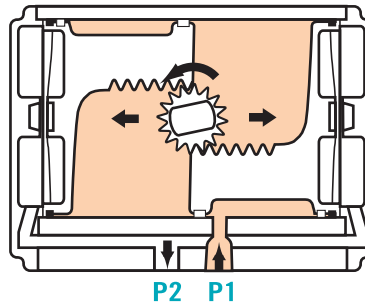

For counterclockwise output, apply pressure to P1, which force the pistons apart. The linear travel of the pistons is converted to a rotation of the drive shaft by the rack to pinion connection. The volume outside each piston is exhausted at P2.

**NOTE:**

When required Reverse Rotation the pistons can be inverted in the housing resulting in a clockwise rotation when pressure is applied to P1

### B. Spring-Return (Top View)

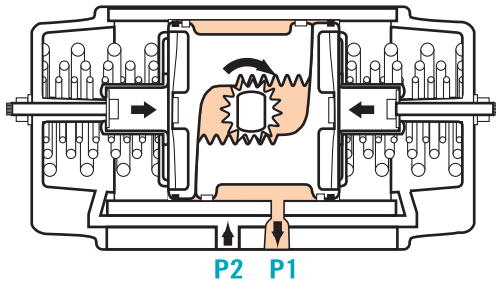

For clockwise output, the volume between the pistons is exhausted at P1, causing the springs to force the pistons together. The volume outside the pistons is vented at P2.

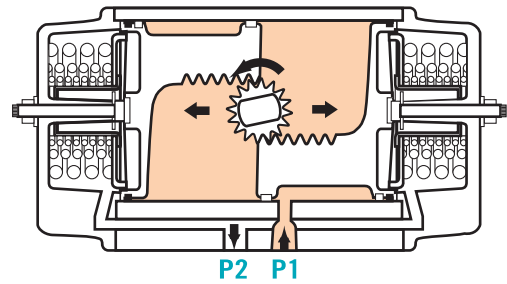

For counterclockwise output, apply pressure P1, which force the pistons apart and compress the springs. The linear travel of the pistons is converted to a rotation of the drive shaft by the rack to pinion connection. The volume outside each piston is exhausted at P2.

**NOTE:**

When required, Reverse Rotation the pistons can be inverted in the housing resulting in a clockwise rotation when pressure is applied to P1 and a counterclockwise rotation when P1 is vented.

## Reduction Adaptors

- Reduce Actuators ISO Output Shaft Broached Square Drive to Smaller ISO Square Stems.
- Iron-Based Powdered Metal Construction for High Strength.
- Fit D-C and S-C Pneumatic Actuators.



### Double-Square Insert Dimensions-mm

INSERT	A	B	C	D	H	R
11M9	11	9	15.0	N/A	17.0	12.5
14M9	14	9	19.1	N/A	20.0	12.5
14M11	14	11	19.1	N/A	20.0	14.5
17M9	17	9	23.1	N/A	24.0	12.5
17M11	17	11	23.1	N/A	24.0	14.5
17M14	17	14	23.1	N/A	24.0	19.2
22M11	22	11	29.6	N/A	30.0	14.5
22M14	22	14	29.6	N/A	30.0	19.2
22M17	22	17	29.6	N/A	30.0	23.3
22M19	22	19	29.6	N/A	30.0	25.8
27M14	27	14	36.0	27.0	29.0	19.2
27M17	27	17	36.0	27.0	29.0	23.3
27M22	27	22	36.0	27.0	29.0	30.0
36M19	36	19	48.0	33.0	35.0	25.8
36M27	36	27	48.0	33.0	35.0	37.0

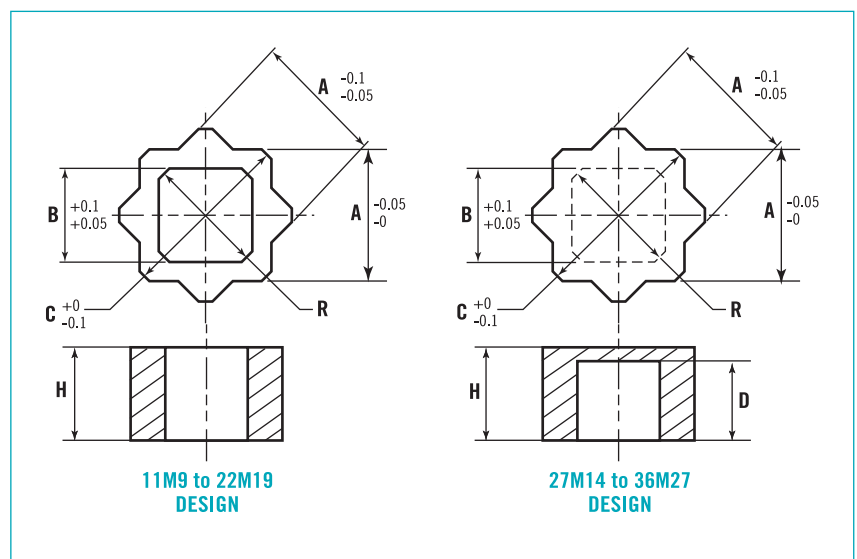

Dimensions-mm

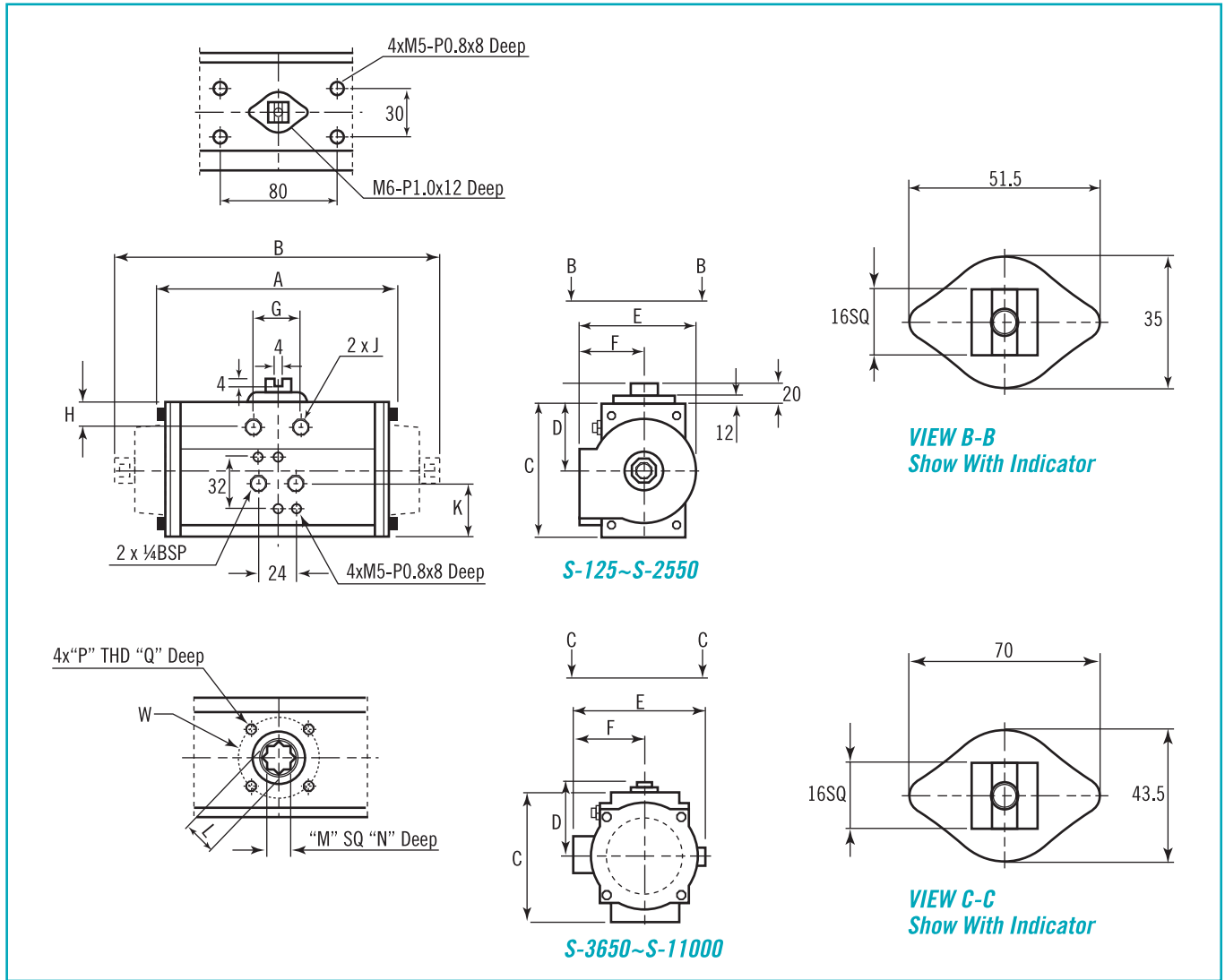

Model	ISO PATTERN	OUTPUT TORQUE AT 80PSI AIR	A	B	C	D	E	F	G	H	J
D-125	F04	125IN-LB	120.0	----	64.0	52.5	62.2	33.7	24.0	11.0	M x P0.8
D-250 / S-250	F04 or F05	250IN-LB	144.3	194.6	79.0	57.7	81.4	47.8	32.5	12.6	M5 x P0.8
D-450 / S-450	F05 & F07	450IN-LB	149.2	205.6	98.0	67.4	95.0	51.5	32.5	13.8	M6 x P1.0
D-1000 / S-1000	F05 & F07	1000IN-LB	183.0	250.0	121.0	79.2	119.0	64.5	46.2	16.6	M8 x P1.25
D-2250 / S-2250	F07 & F10	2250IN-LB	259.6	355.0	141.0	89.5	140.5	75.5	54.0	18.6	M10 x P1.5
D-3650 / S-3650	F10 & F12	3650IN-LB	304.3	422.0	176.0	99.1	185.2	105.5	79.7	27.3	M12 x P1.75
D-5000 / S-5000	F10 & F12	5000IN-LB	364.4	487.0	196.0	116.5	204.8	107.8	79.4	28.3	M12 x P1.75
D-11000 / S-11000	F14	11000IN-LB	490.0	642.0	243.7	138.5	238.2	125.0	95.3	35.8	M16 x P2.0

Model	ISO PATTERN	OUTPUT TORQUE AT 80PSI AIR	K	L	M	N	P	Q	W
D-125	F04	125IN-LB	23.5	12.5	9.0	10.0	M5 x P0.8	8.0	42.0
D-250 / S-250	F04 or F05	250IN-LB	29.7	14.5	11.0	17.0	M5 x P0.8 / M6 x P1.0	8.0 / 10.0	42.0 / 50.0
D-450 / S-450	F05 & F07	450IN-LB	30.2	18.8	14.0	21.0	M6 x P1.0 / M8 x P1.25	10.0 / 12.0	50.0 / 70.0
D-1000 / S-1000	F05 & F07	1000IN-LB	33.5	23.0	17.0	25.5	M6 x P1.0 / M8 x P1.25	10.0 / 12.0	50.0 / 70.0
D-2250 / S-2250	F07 & F10	2250IN-LB	39.0	29.5	22.0	31.0	M8 x P1.25 / M10 x P1.5	12.0 / 15.0	70.0 / 102.0
D-3650 / S-3650	F10 & F12	3650IN-LB	97.4	35.5	27.0	35.0	M10 x P1.5 / M12 x P1.75	15.0 / 19.0	102.0 / 125.0
D-5000 / S-5000	F10 & F12	5000IN-LB	99.0	35.5	27.0	35.0	M10 x P1.5 / M12 x P1.75	15.0 / 19.0	102.0 / 125.0
D-11000 / S-11000	F14	11000IN-LB	124.7	47.5	36.0	45.0	M16 x P2.0	24.0	140.0

## Torque Table (in. lbs)

### DA Series: Double-Acting Actuators

Model	Air Supply Pressure (unit: psig)				
	40	60	80	100	120
	Air Torque Output (in.lbs)				
125	63	94	125	156	188
250	125	187	250	312	375
450	225	337	450	562	675
1000	500	750	1000	1250	1500
2250	1125	1687	2250	2812	3375
3650	1825	2738	3650	4563	5475
5000	2500	3750	5000	6250	7500
11000	5500	8250	11000	13750	16500

### SA Series: Spring-Return Actuators

Model No.		Spring Torque Output		Air Supply Pressure (unit: psig)									
				40		60		80		100		120	
				Air Torque Output (in.lbs)									
Basic	Spring Set	Start	End	Start	End	Start	End	Start	End	Start	End	Start	End
250	SR 2	69	45	76	47	138	109	201	172	263	234	326	312
	SR 3	104	67			113	70	176	133	229	195	301	258
	SR 4	140	90			88	31	151	93	213	156	276	218
	SR 5	175	112					126	54	189	116	251	179
	SR 6	209	135							164	77	227	139
	450	SR 2	126	81	135	83	248	196	361	309	473	421	586
SR 3		190	121			203	125	316	238	428	350	541	463
SR 4		254	162			158	54	271	167	383	279	496	392
SR 5		317	202					226	96	339	209	451	321
SR 6		381	243							293	137	406	251
1000		SR 2	279	179	300	184	549	433	798	682	1048	931	1297
	SR 3	418	270			449	278	698	526	947	775	1196	1025
	SR 4	559	360			350	120	599	371	848	618	1097	867
	SR 5	698	450					500	212	749	464	998	710
	SR 6	839	540							650	304	899	557
	2250	SR 2	659	394	690	395	1253	958	1816	1521	2379	2084	2939
SR 3		990	590			1034	591	1596	1154	2159	1717	2722	2280
SR 4		1320	787			816	226	1379	788	2029	1351	2505	1914
SR 5		1650	984					1161	424	1724	984	2287	1549
SR 6		1980	1181							1506	621	2069	1181
3650		SR 2	1053	607	1152	659	2063	1570	2975	2482	3886	3393	4797
	SR 3	1573	912			1726	996	2637	1907	3549	2819	4460	3730
	SR 4	2091	1217			1388	423	2300	1335	3211	2246	4123	3157
	SR 5	2625	1519					1967	744	2878	1655	3789	2566
	SR 6	3144	1824							2540	1082	3452	1994
	5000	SR 2	1560	785	1590	803	2780	1990	3970	3180	5160	4380	6350
SR 3		2340	1180			2380	1200	3570	2400	4760	3590	5960	4780
SR 4		3130	1570			1980	414	3180	1600	4370	2800	5560	3990
SR 5		3910	1960					2780	815	3970	2010	5160	3200
SR 6		4690	2360							3570	1220	4760	2410
11000		SR 2	3400	1720	3460	1760	6060	4360	8660	6960	11300	9560	13900
	SR 3	5100	2570			5200	2650	7790	5240	10400	7840	13000	10400
	SR 4	6790	3430			4330	932	6930	3530	9520	6130	12100	8730
	SR 5	8490	4290					6060	1810	8660	4410	11300	7010
	SR 6	10200	5150							7790	2700	10400	5300

## Ordering Information

Model	DA	Double-Acting Actuators		SA	Spring-Return Actuators		
↓	↓	Code		Actuators Size ,please refer to Model Table			
		(1)125 (2) 250 (3) 450 (4) 1000 (5) 2250 (6) 3650 (7) 5000 (8) 11000		Code		Spring Set (only for SA series)	
		(1) SR 2 (2) SR 3 (3) SR 4 (4) SR 5 (5) SR 6		Code		Reduction Adaptors	
		Please refer to the <i>Double Square Actuator Inserts Table</i> and fill in the Insert Model of your request directly.		0	Without		
↓ ↓ ↓ ↓							<b>Complete Ordering Code</b>

**Ordering code example:**  
**SA-3650-SR 3-0**  
 → SA =Model  
 → 3650=Model Table  
 → SR 3=Spring Set  
 → 0=Without Reduction Adaptors