

# FULL BORE SAFETY VALVES

## FSF-1P/FSF-2P

### Technical Data

Low lift safety valves

Material: Body-FC, Valve seat-CF8

Orifice size: 1"(25mm), 1½"(40mm), 2"(50mm)

Working pressure: 1~10 kgf/cm<sup>2</sup>, 11~20 kgf/cm<sup>2</sup>

Working temp.: -5°C~196°C

Working fluid: Noncorrosive gas, air, steam

### Blowout Capacity Table

set pressure	Steam Blowout Cap. (kg/h)		
	1"(25)	1½"(40)	2"(50)
1 kgf/cm <sup>2</sup>	67.90	156.9	271.7
2 kgf/cm <sup>2</sup>	102.4	236.6	409.5
3 kgf/cm <sup>2</sup>	136.9	316.2	547.4
4 kgf/cm <sup>2</sup>	171.3	395.8	685.2
5 kgf/cm <sup>2</sup>	205.8	475.4	823.1
6 kgf/cm <sup>2</sup>	240.2	555.0	960.9
7 kgf/cm <sup>2</sup>	274.7	634.7	1099
8 kgf/cm <sup>2</sup>	309.2	714.3	1237
9 kgf/cm <sup>2</sup>	343.6	793.9	1374
10 kgf/cm <sup>2</sup>	378.1	893.5	1512
11 kgf/cm <sup>2</sup>	412.5	953.2	1650
12 kgf/cm <sup>2</sup>	447.0	1033	1788
13 kgf/cm <sup>2</sup>	481.5	1112	1926
14 kgf/cm <sup>2</sup>	515.9	1192	2064
15 kgf/cm <sup>2</sup>	550.4	1272	2202
16 kgf/cm <sup>2</sup>	584.9	1351	2239
17 kgf/cm <sup>2</sup>	619.3	1431	2477
18 kgf/cm <sup>2</sup>	653.8	1511	2615
19 kgf/cm <sup>2</sup>	688.2	1590	2753
20 kgf/cm <sup>2</sup>	722.7	1670	2891

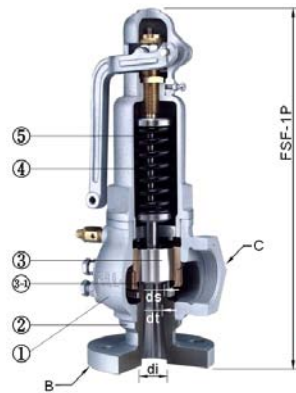

FSF-1P  
Lever 1"~2"

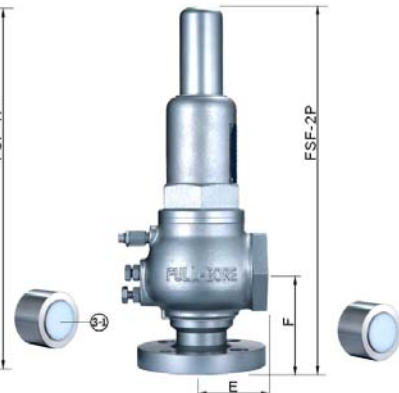

FSF-2P  
Sealing 1"~2"

### Dimensions

SEALING SERIES				
ITEM	SIZE	1"	1½"	2"
FSF-1P		310	385	440
FSF-2P		310	385	440
Inlet B		1"	1½"	2"
Outlet C		1¼"	2"	2½"
Inlet Orifice di		25	40	50
Throat Orifice dt		19	29	38
Valve Seat Orifice ds		22.5	34.0	44.0
Effective Discharge area mm <sup>2</sup>		283.5	660.5	1134.1

(unit:mm)

LEVER SERIES				
ITEM	SIZE	1"	1½"	2"
E		60	70	85
F		85	100	115
Lift		4.8	7.3	9.5
Wt. kg		6.5	12	17.5

### General Material List

NO.	Parts Name	Type	
		FSF-1P Lever	FSF-2P Sealing
1.	Valve Body	FC	
2.	Valve Seat	CF8	
3.	Disc	SUS304	
3-1.	Soft Seal	Teflon (PTFE)	
4.	Spring	Steel	
5.	Stem	SUS304	
Working Pressure		1~10 kgf/cm <sup>2</sup>	11~20 kgf/cm <sup>2</sup>
Working Temp.		-5°C~196°C	
Working Fluid		Noncorrosive gas, air, steam	

### Ordering Information

FSF-1P / FSF-2P	Code	Valve Seat		
↓	0	CF8		
		Code	Pressure Rating	
	1	1~10 kg/cm <sup>2</sup>	2	11~20 kg/cm <sup>2</sup>
	Code	Size	(A) 1"NPT (B) 1½"NPT (C) 2"NPT	
↓				
Complete Ordering Code				