

# AIR ELIMINATOR

## STA

### Principles

a. When the float lowers down, the release valve opens. Liquid fluid flows through the strainer eliminator. Air should be separated from liquid to upper port, and then relieved to outside through the release valve.

b. When float rises, the release valve is closed. When the float is rising as liquid level increases, the release valve closes at the same time.

\* Please consult to New-Flow regarding the dimension .

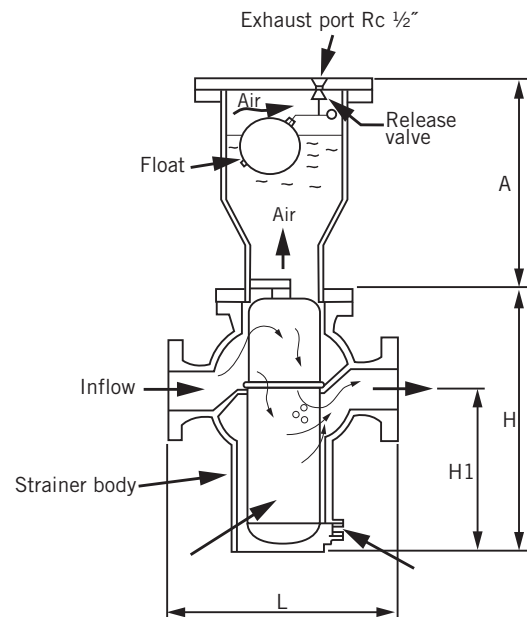

### Installation

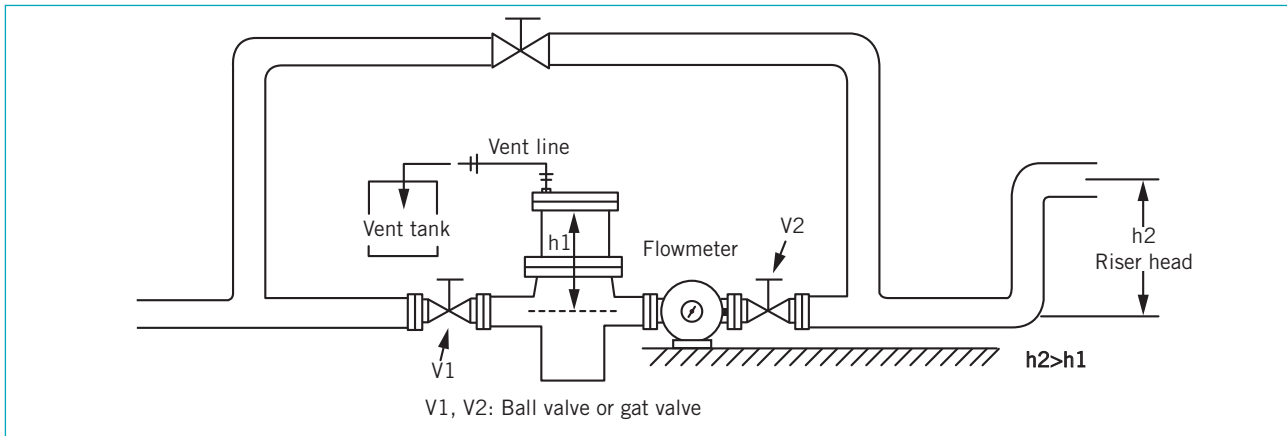

### Part List

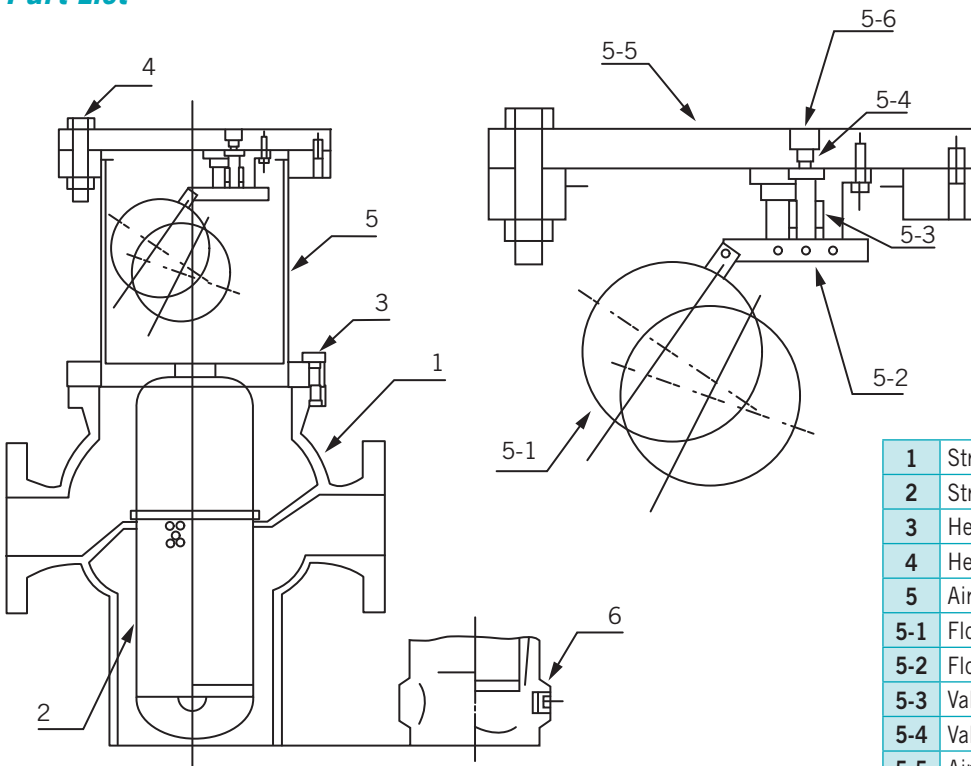

1	Strainer Body
2	Strainer Screen
3	Hex Bolt for Body & Air Eliminator
4	Hex Bolt for Cover of Air Eliminator
5	Air Eliminator Parts
5-1	Float (SS304)
5-2	Float Alarm Rod (SS304)
5-3	Valve Stem (SS304) with Viton Plug
5-4	Valve Seat (SS304)
5-5	Air Eliminator Cover
5-6	Vent Port
6	Drain Port